

FLOOR PLAN

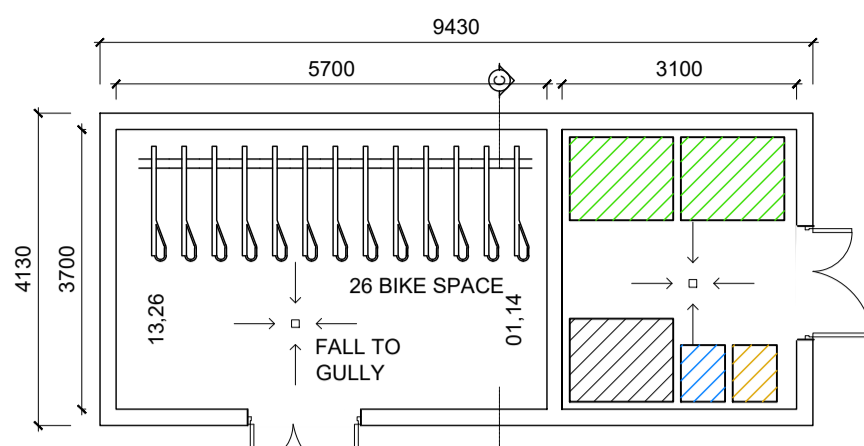

Bin / Bike Store - Type 1A

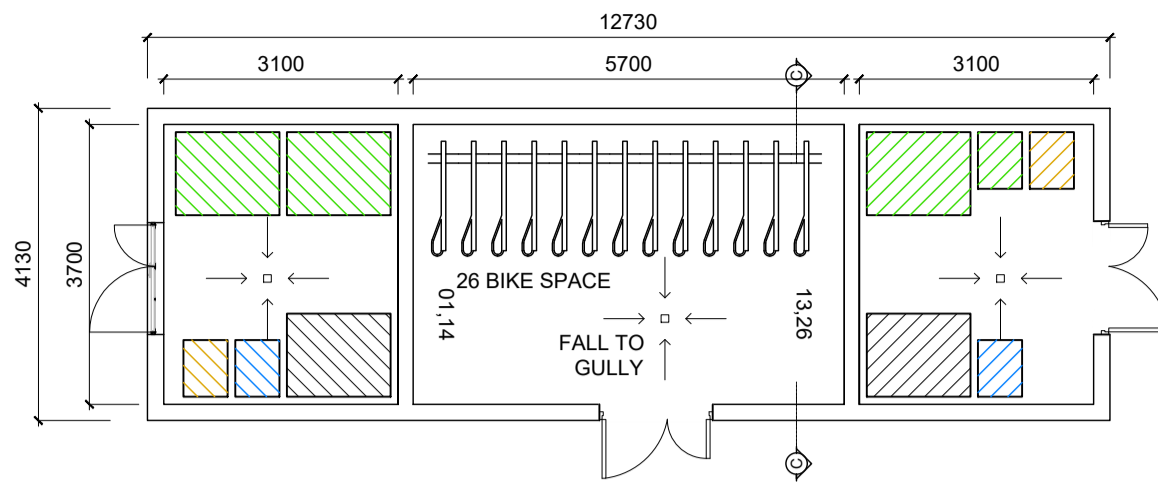

Bin / Bike Store - Type 1B

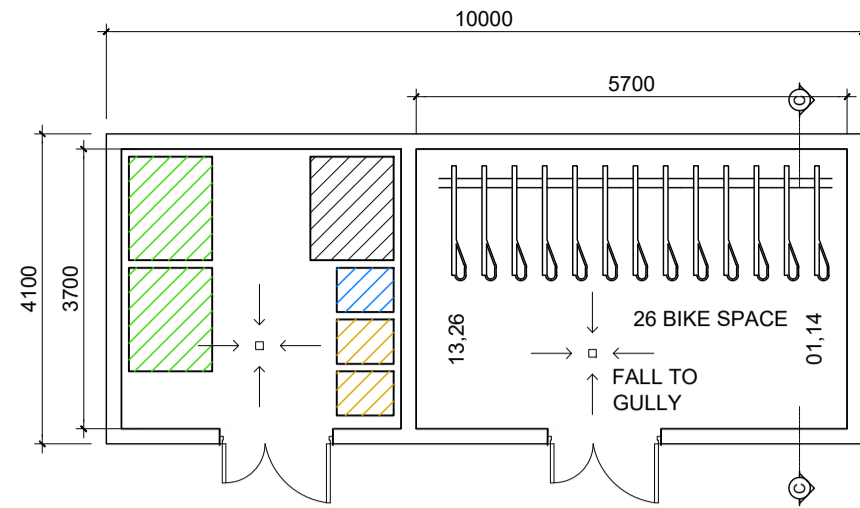

Bin / Bike Store - Type 1C

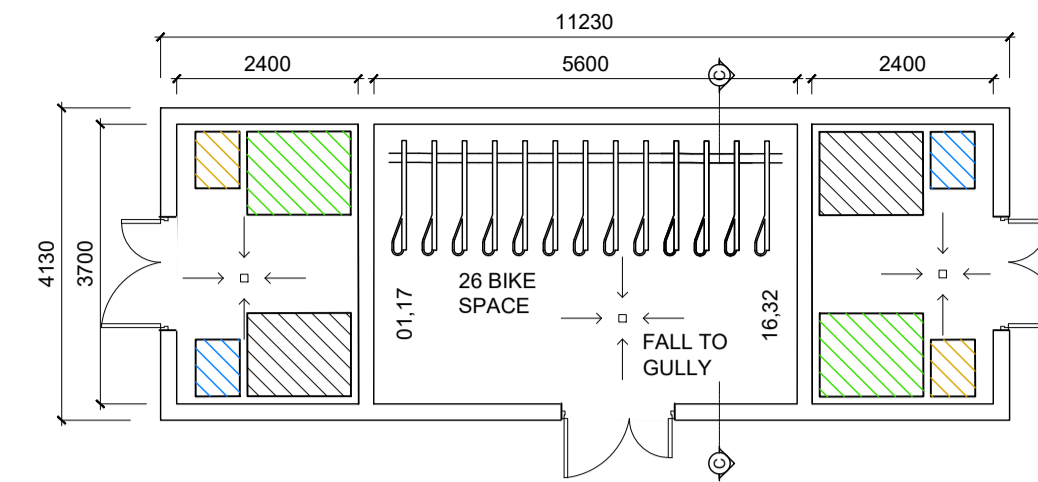

Bin / Bike Store - Type 1D

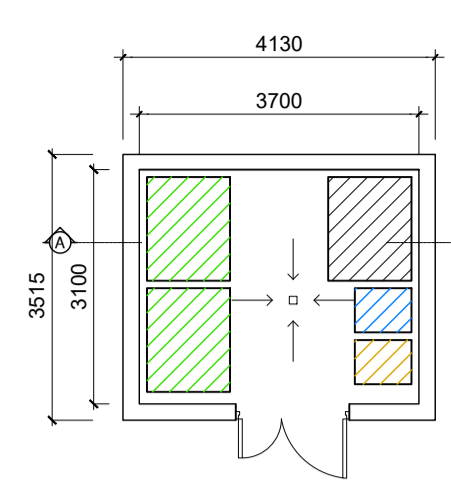

Bin Store - Type 2

GENERAL NOTES

THIS DRAWING TO BE READ IN CONJUNCTION WITH ARCHITECT'S DRAWINGS, CONSULTANT ENGINEER'S DRAWINGS AND SPECIFICATIONS, AND LANDSCAPE ARCHITECT'S DRAWINGS AND SPECIFICATIONS.

OUTLINE SPECIFICATION:

- BRICK BLOCK WALLS IN SELECTED COLOUR WITH ELEMENTS OF RENDER AND/OR TIMBER OVER CLADDING
- LOUVERED TIMBER / ALUMINIUM DOORS
- SLATTED TIMBER ROOF OVER BIN & BIKE STORE.
- ENCLOSURE TO BE DRAINED AND PROVIDED WITH A POWER AND WATER SUPPLY



FRONT ELEVATIONS

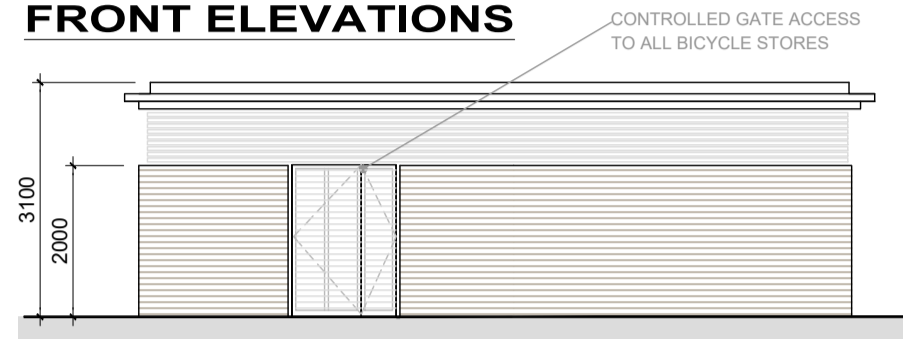

Bicycle & Bin Store - Type 1A

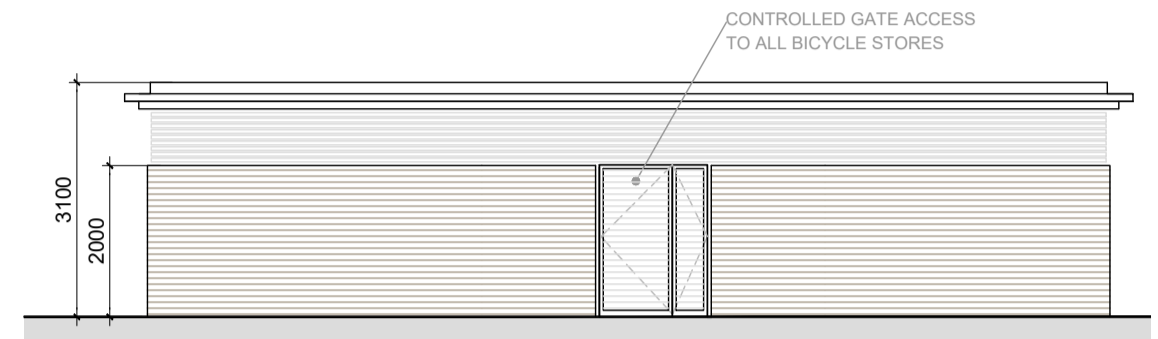

Bicycle & Bin Store - Type 1B

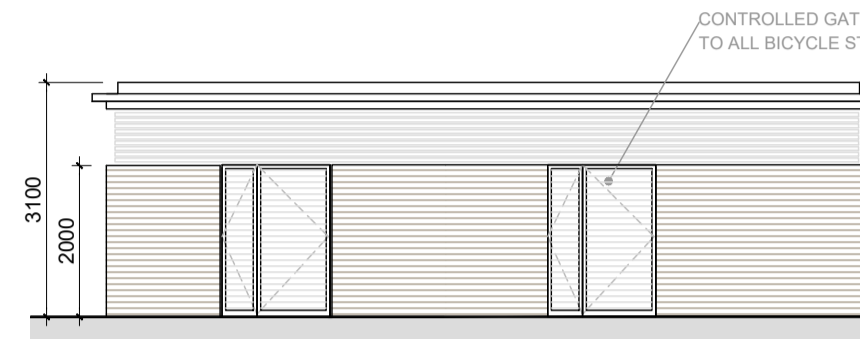

Bicycle & Bin Store - Type 1C

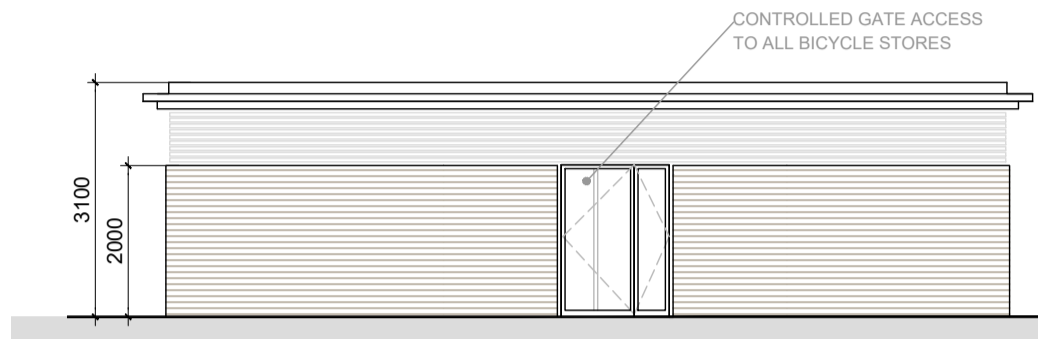

Bicycle & Bin Store - Type 1D

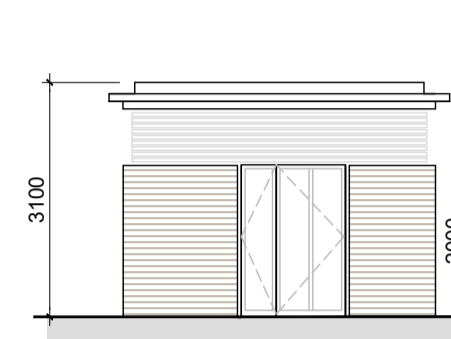

Bin Store - Type 2

REAR ELEVATIONS

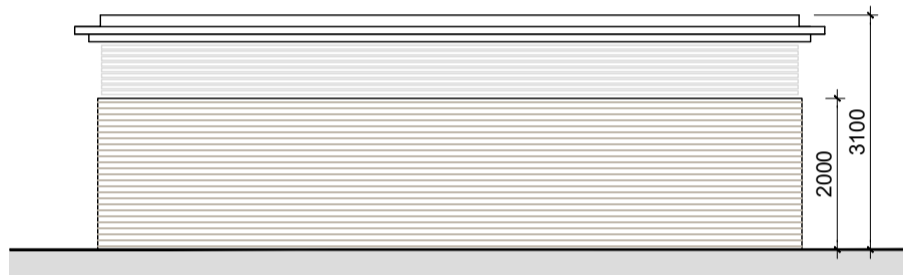

Bicycle & Bin Store - Type 1A

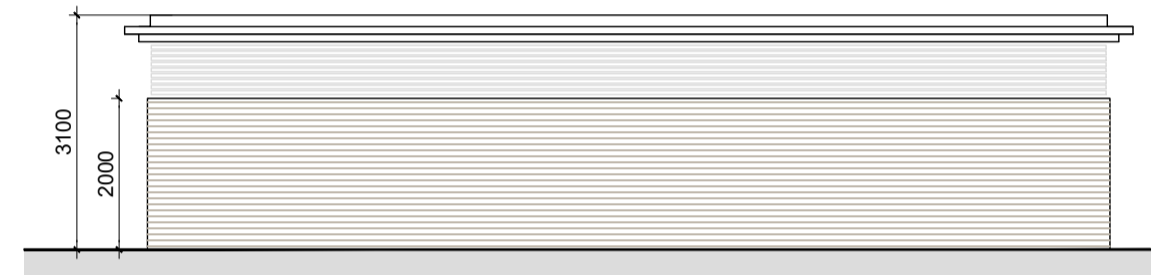

Bicycle & Bin Store - Type 1B

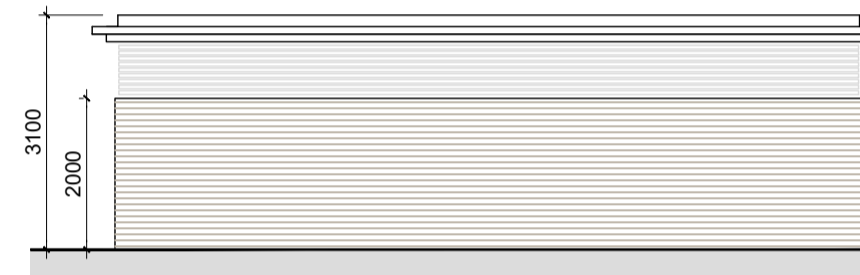

Bicycle & Bin Store - Type 1C

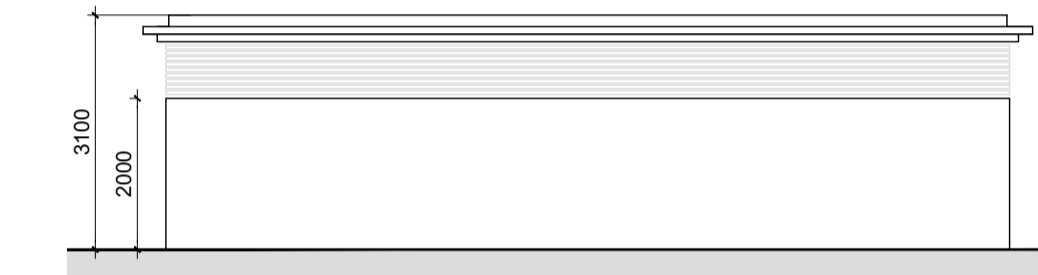

Bicycle & Bin Store - Type 1D

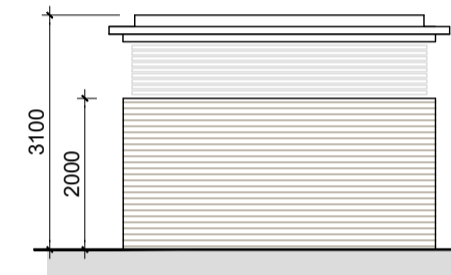

Bin Store - Type 2

FLOOR PLAN

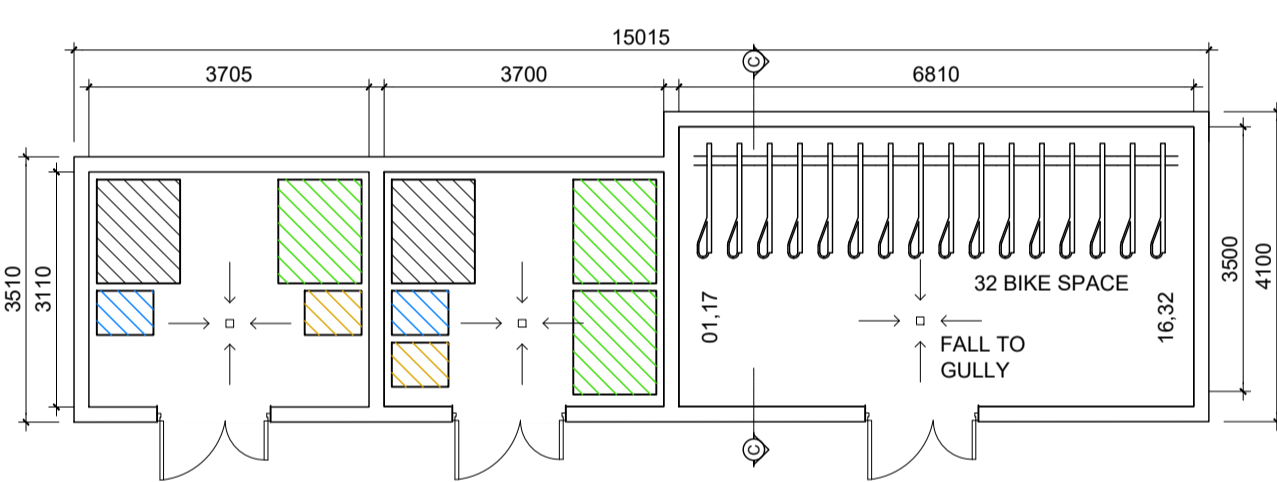

Bin / Bike Store - Type 3A

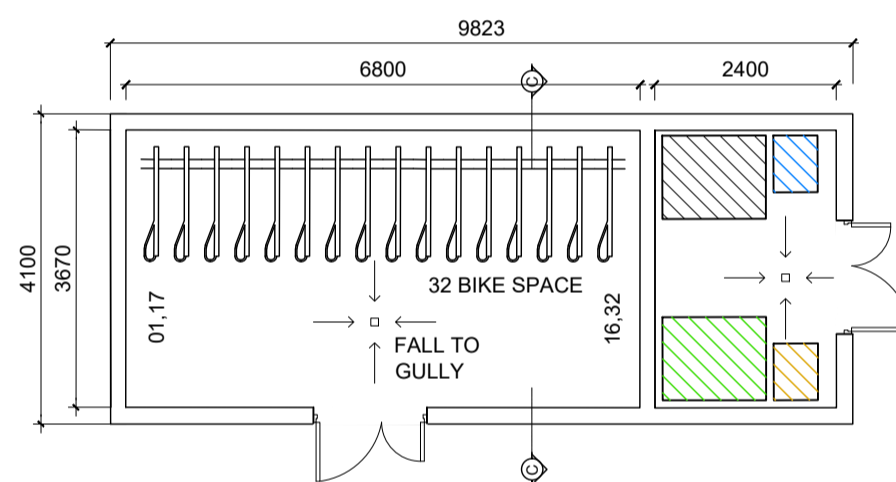

Bin / Bike Store - Type 3B

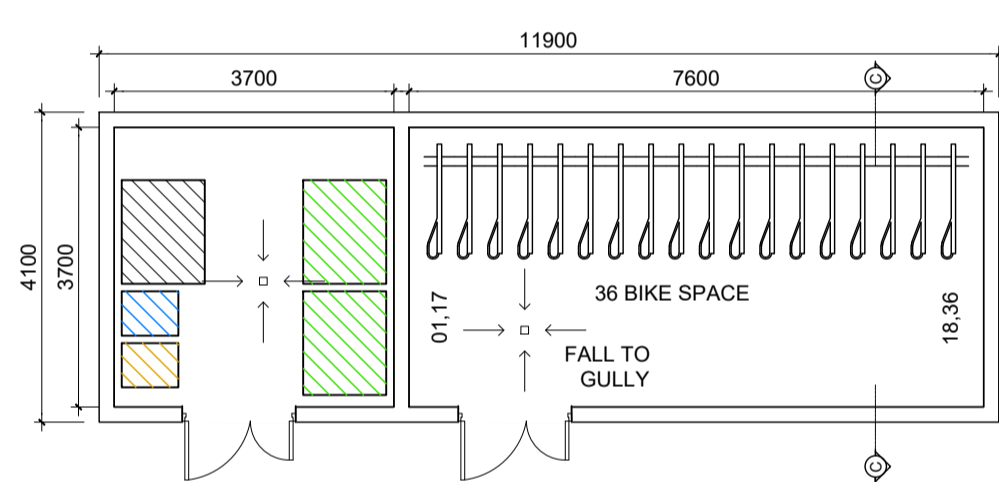

Bin Store - Type 4A

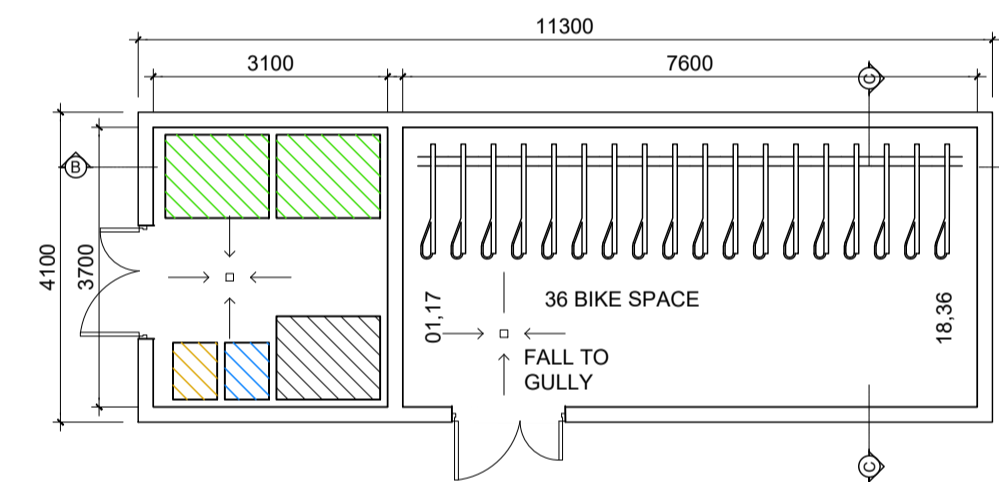

Bin / Bike Store - Type 4B

FRONT ELEVATIONS

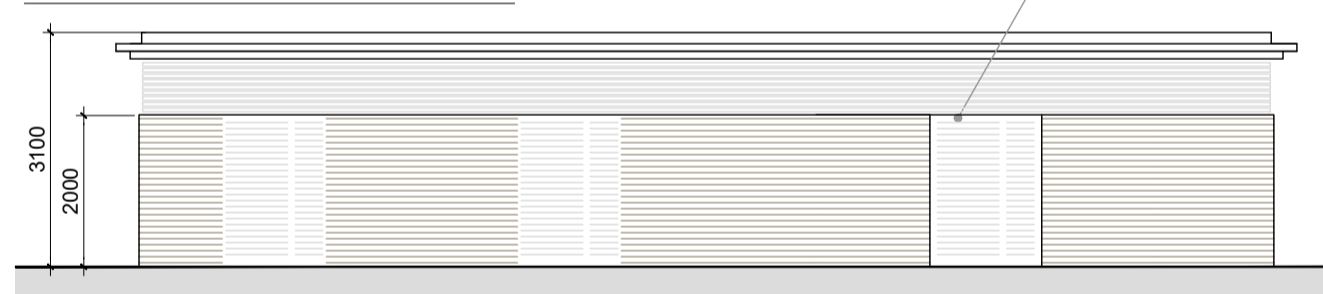

Bicycle & Bin Store - Type 3A

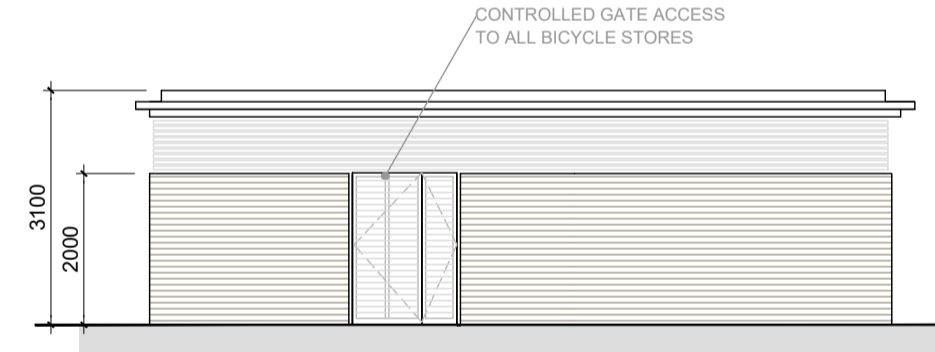

Bicycle & Bin Store - Type 3B

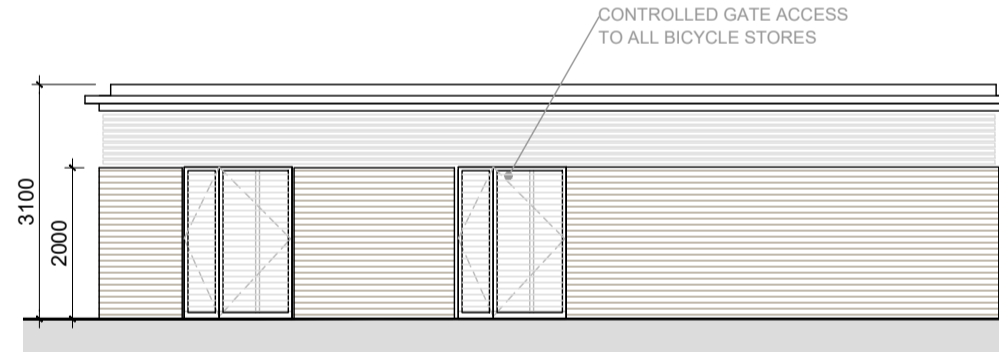

Bicycle & Bin Store - Type 4A

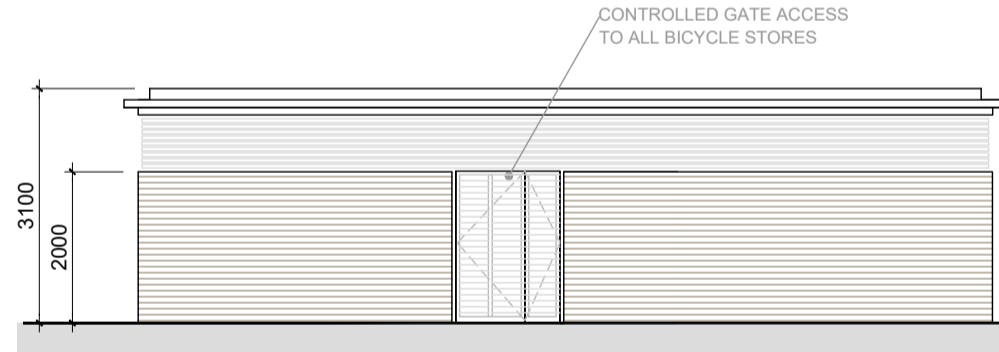

Bicycle & Bin Store - Type 4B

REAR ELEVATIONS

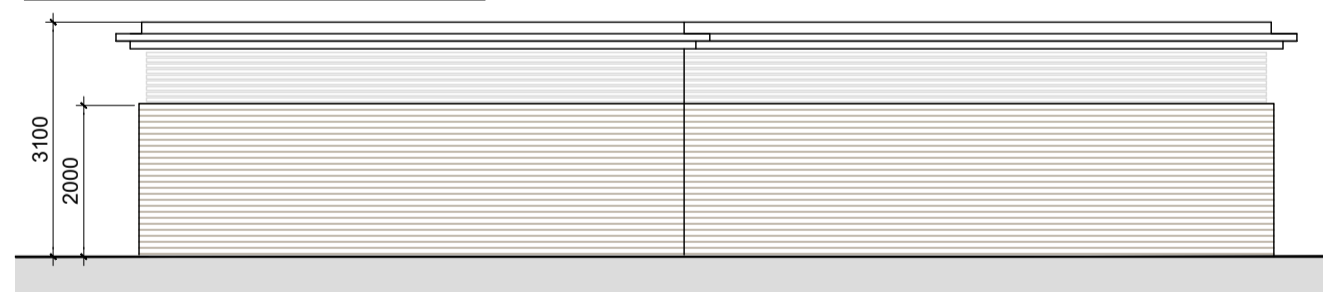

Bicycle & Bin Store - Type 3A

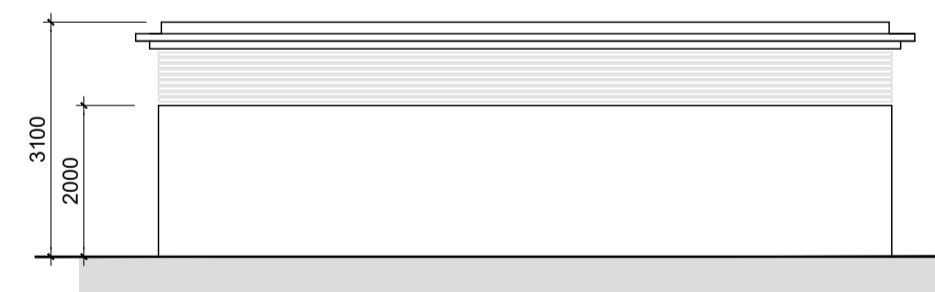

Bicycle & Bin Store - Type 3B

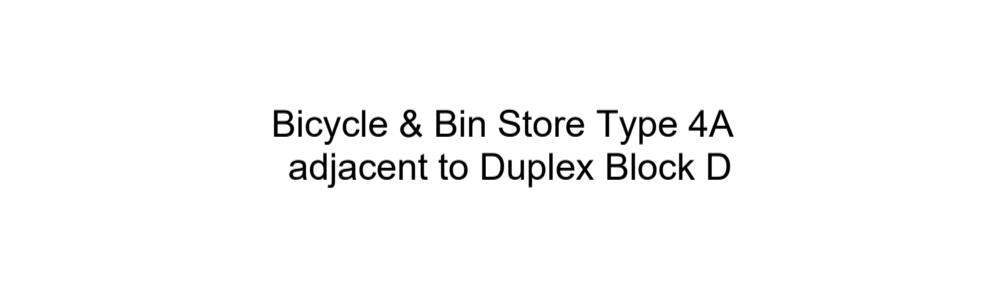

Bicycle & Bin Store Type 4A adjacent to Duplex Block D

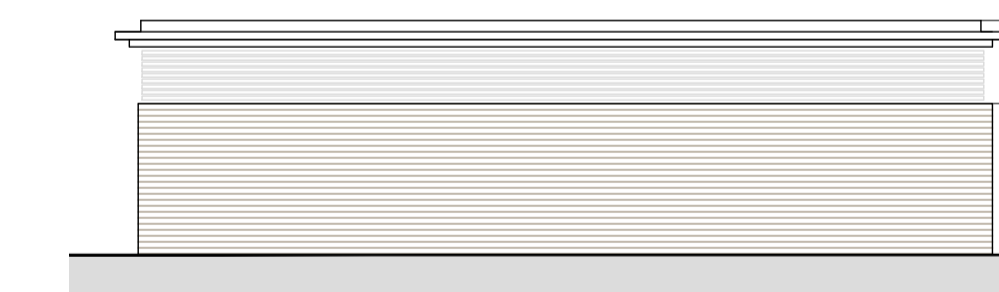

Bicycle & Bin Store - Type 4B



SIDE ELEVATIONS

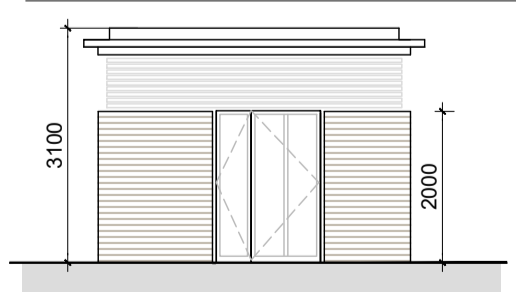

Bicycle & Bin Store Types 1A, 1B, 1D, 3B, 4B (Mirrored where applicable)

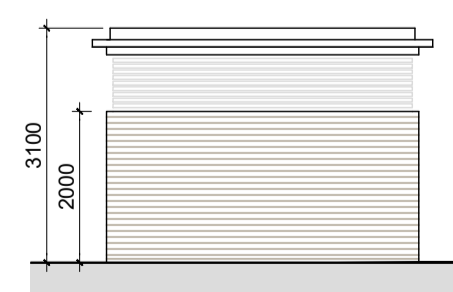

Bicycle & Bin Store Types 1A, 4B

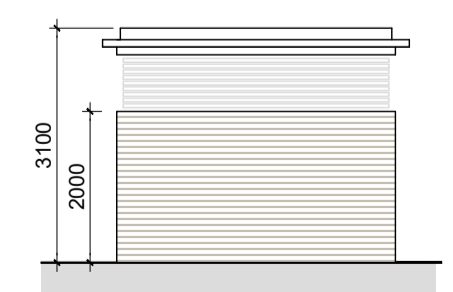

Bicycle & Bin Store Types 2

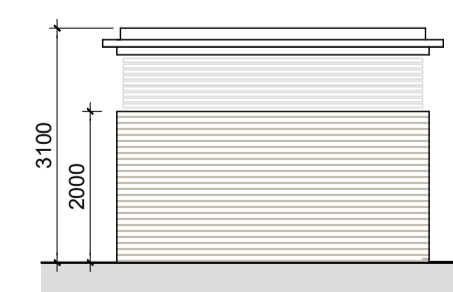

Bicycle & Bin Store Types 1C, 3A, 3B, 4A

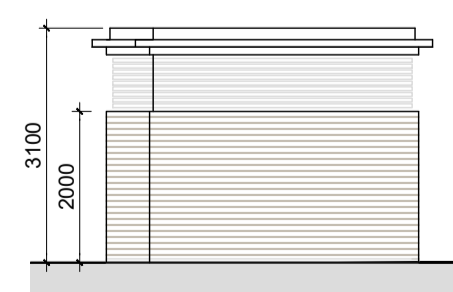

Bicycle & Bin Store Types 4A

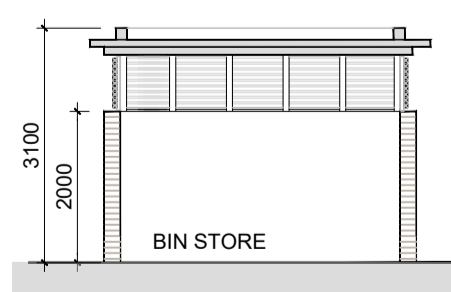

SECTION A-A

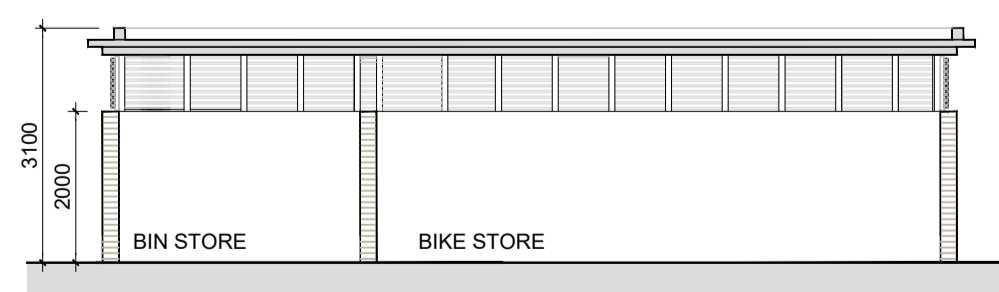

SECTION B-B

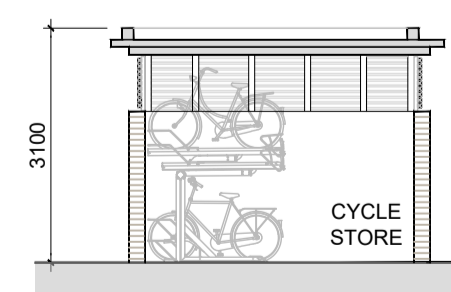

SECTION C-C

NOTES:

DO NOT SCALE FROM DRAWINGS. WORK TO FIGURED DIMENSIONS ONLY. ARCHITECT TO BE NOTIFIED OF ALL DISCREPANCIES.

CLIENT:		REVISIONS	
CAIRN CAIRN Homes Properties Ltd		DATE	DESCRIPTION

	PROJECT TITLE:	DATE:	DRAWN BY:
	SHD AT HOLYBANKS, SWORDS	Mar'22	IDF
	DRAWING TITLE:	SCALE:	REVISION:
	BICYCLE & BIN STORE	1:100@A1	
	JOB NO:	DRAWING NO:	
	19022	PL63	